

THE CLARE



PROPERTY FEATURES

2438 sq. ft.
3 Bed | 2.5 Bath | 2 Car
Flex Room | Rear Patio | Storage
Opt. Fireplace or Fireplace w/ Cabinets | Opt. Luxury
Owner's Suite | Option Bath #2 Shower | Opt. Bedroom #4/
Bath #3 | Opt. Pocket Office | Opt. Study

VILLAGE HOMES

817.737.3377 | HOMESOFCHARACTER.COM

KARIS
GET CONNECTED



*Actual plan may vary slightly from artist's interpretation.

{TIMELESS CRAFTSMANSHIP | INNOVATIVE LIVING}

C.25R.2438 CLARE

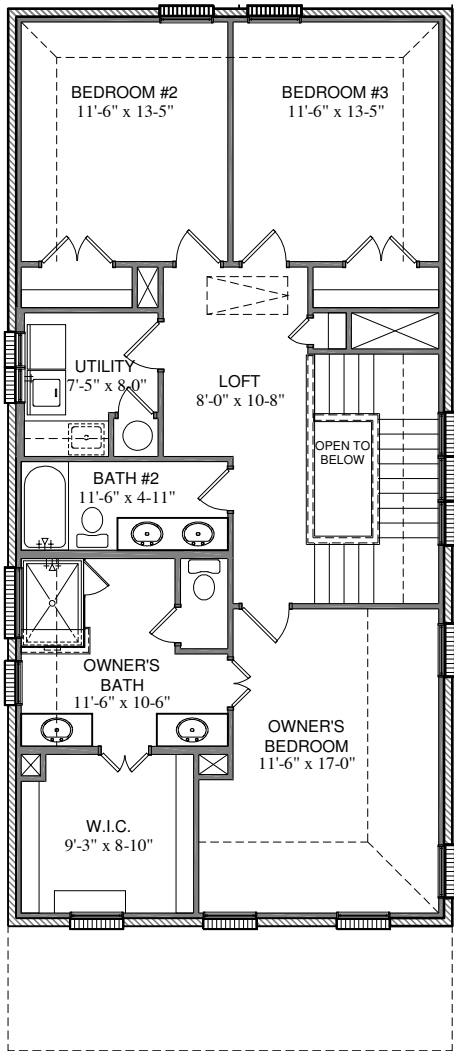

SECOND FLOOR PLAN

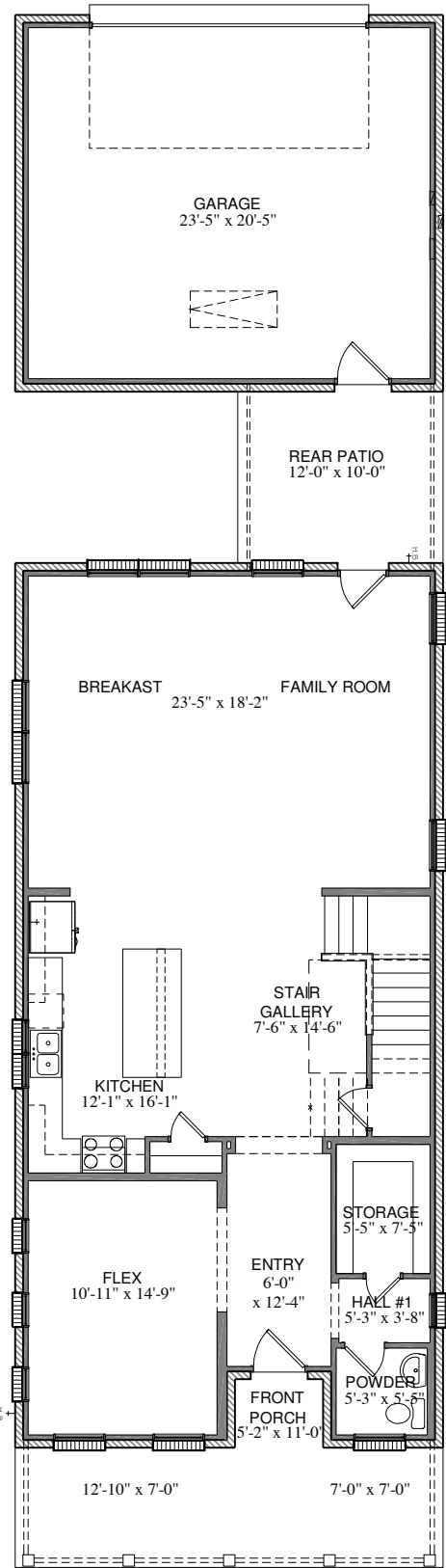

FIRST FLOOR PLAN

**ELEVATION "A"
SQUARE FOOTAGE TOTALS**

1271	1ST FLOOR
1167	2ND FLOOR
316	COVERED PORCHES
550	GARAGE
3304	TOTAL A.U.R.

All plans and elevations are subject to change without prior notice. All Village Homes floor plans & elevations are copyrighted. Village Homes will enforce copyright laws to their fullest extent. All plan numbers are approximations of square footage and may vary with alternate elevations.

Please note: In an effort to continually improve our floor plans and elevations, Village Homes reserves the right to make alterations to the designs without prior notice.

C.25R.2438 CLARE

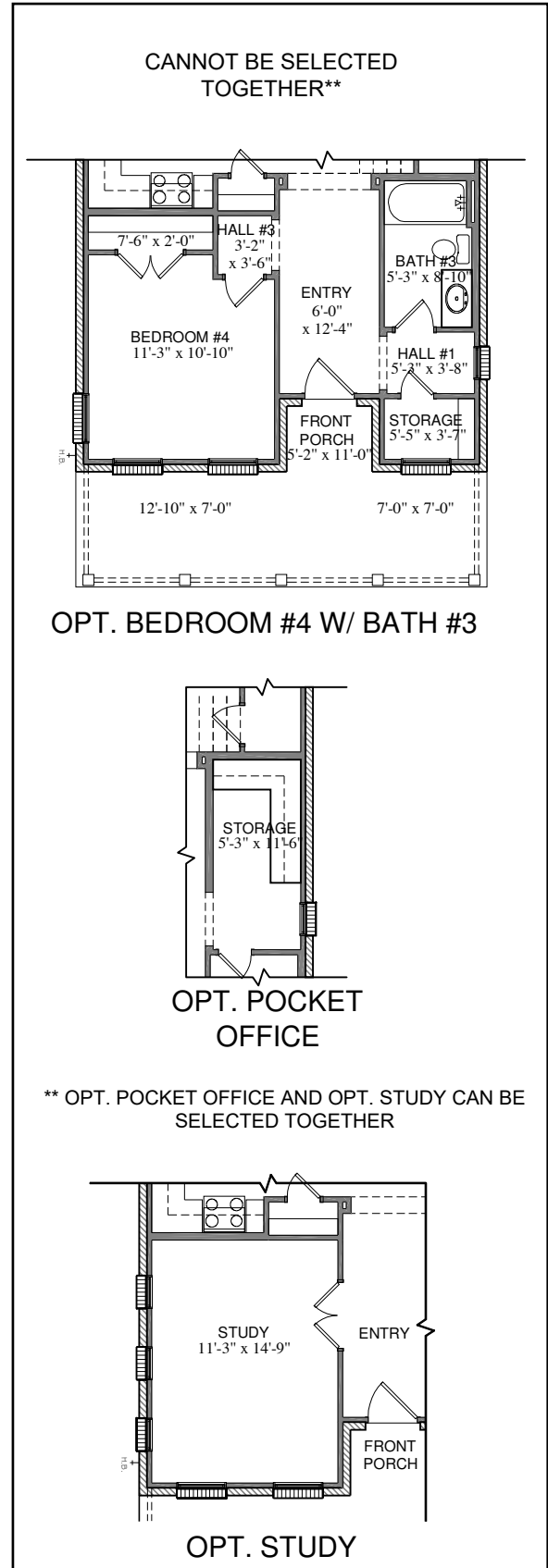
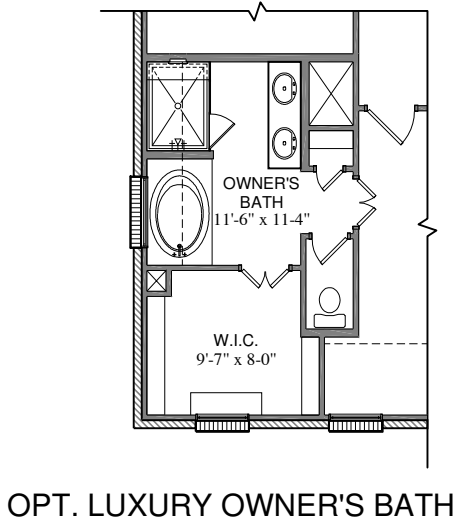
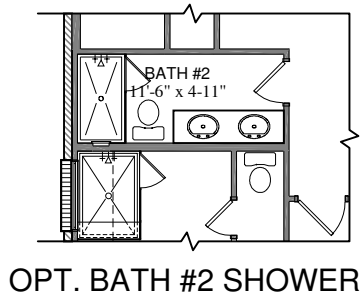
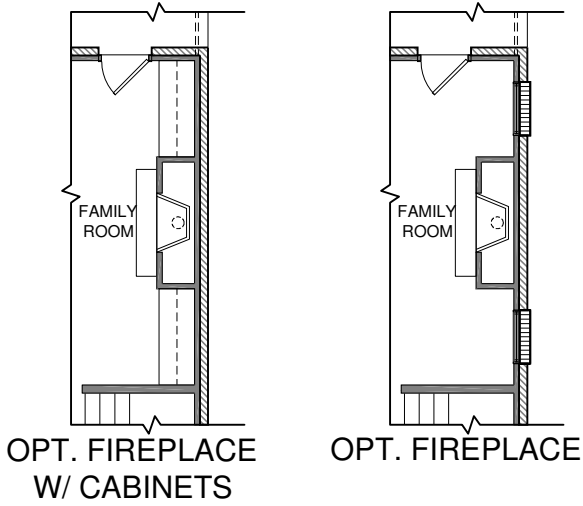

ELEVATION "A"

All plans and elevations are subject to change without prior notice. All Village Homes floor plans & elevations are copyrighted. Village Homes will enforce copyright laws to their fullest extent. All plan numbers are approximations of square footage and may vary with alternate elevations.

Please note: In an effort to continually improve our floor plans and elevations, Village Homes reserves the right to make alterations to the designs without prior notice.

C.25R.2438 CLARE

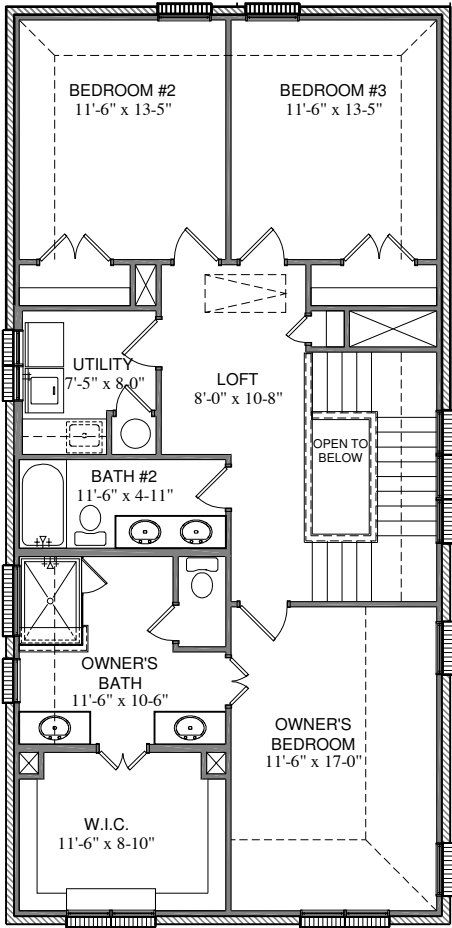

SECOND FLOOR PLAN

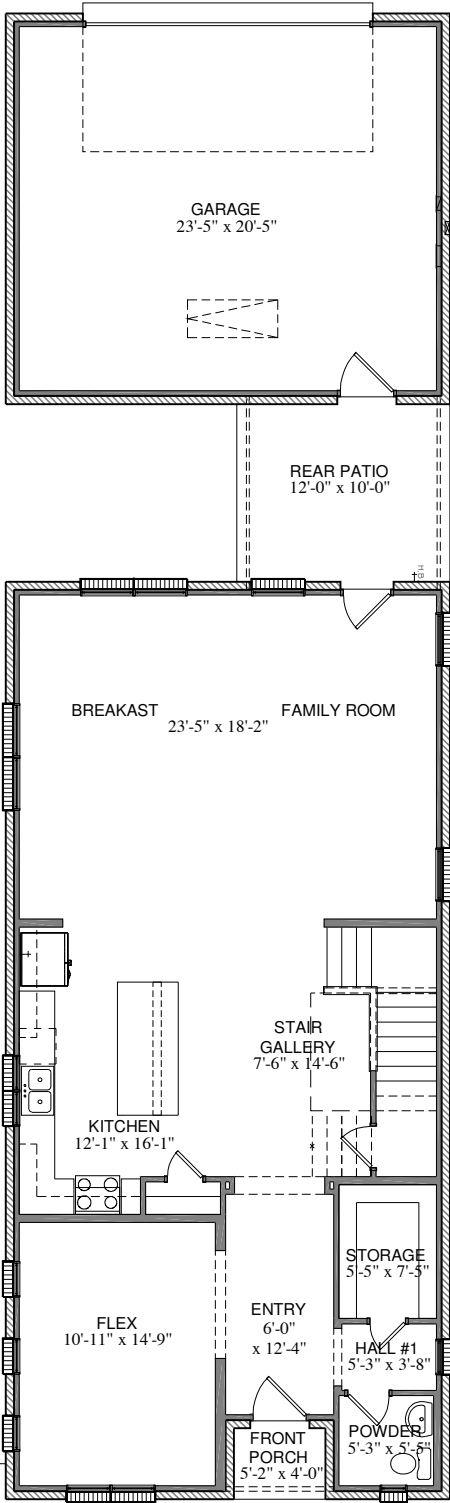

FIRST FLOOR PLAN

**ELEVATION "B"
SQUARE FOOTAGE TOTALS**

1271	1ST FLOOR
1167	2ND FLOOR
141	COVERED PORCHES
550	GARAGE
3129	TOTAL A.U.R.

All plans and elevations are subject to change without prior notice. All Village Homes floor plans & elevations are copyrighted. Village Homes will enforce copyright laws to their fullest extent. All plan numbers are approximations of square footage and may vary with alternate elevations.

Please note: In an effort to continually improve our floor plans and elevations, Village Homes reserves the right to make alterations to the designs without prior notice.

C.25R.2438
CLARE

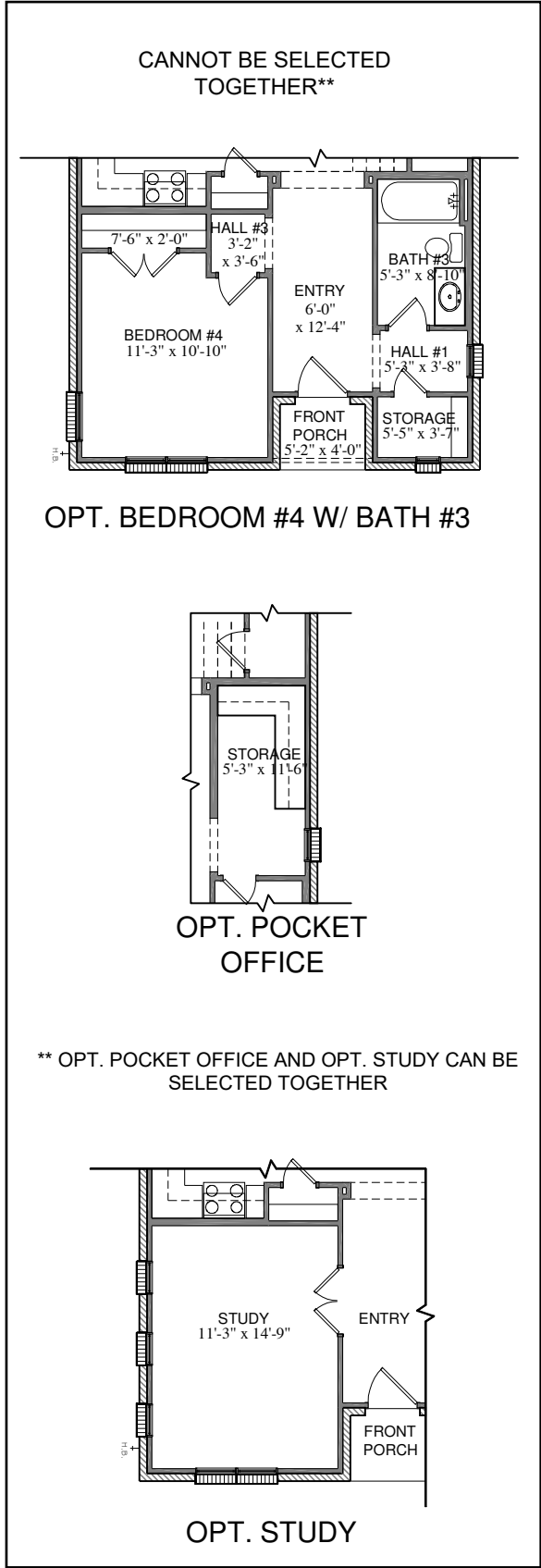
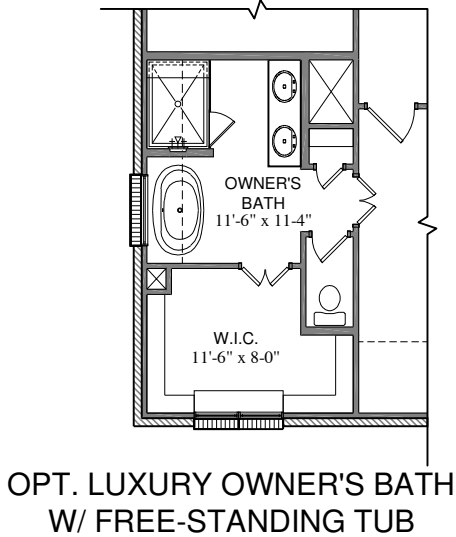
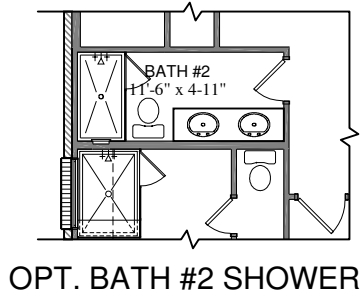
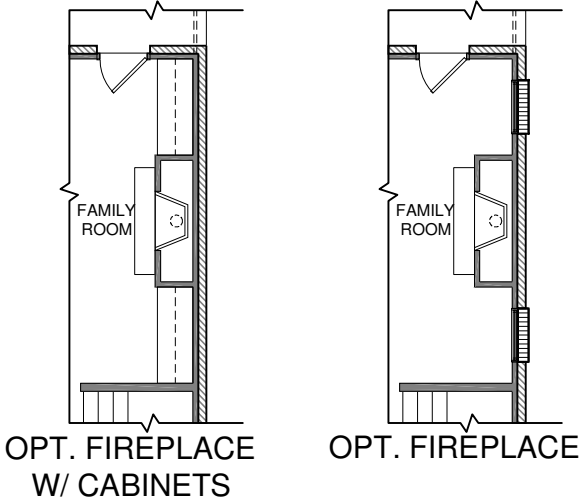

ELEVATION "B"

All plans and elevations are subject to change without prior notice. All Village Homes floor plans & elevations are copyrighted. Village Homes will enforce copyright laws to their fullest extent. All plan numbers are approximations of square footage and may vary with alternate elevations.

Please note: In an effort to continually improve our floor plans and elevations, Village Homes reserves the right to make alterations to the designs without prior notice.

C.25R.2438 CLARE

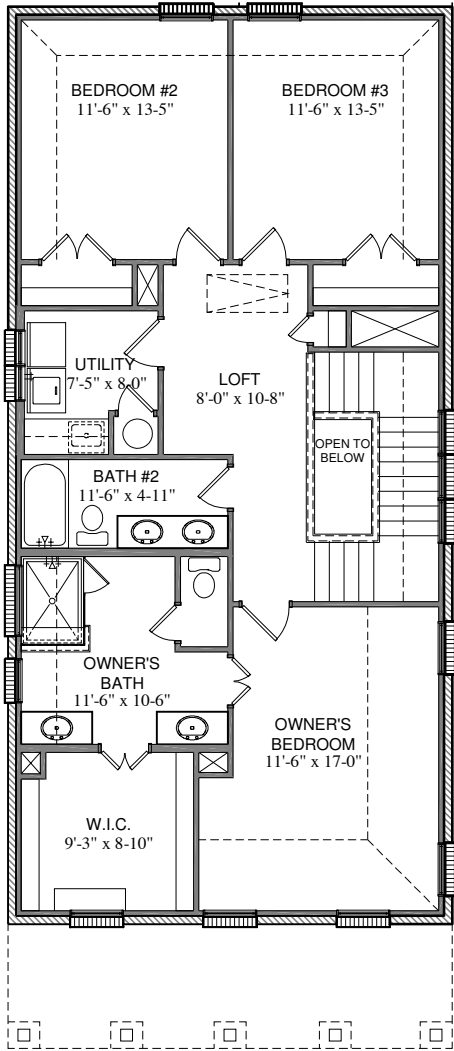

SECOND FLOOR PLAN

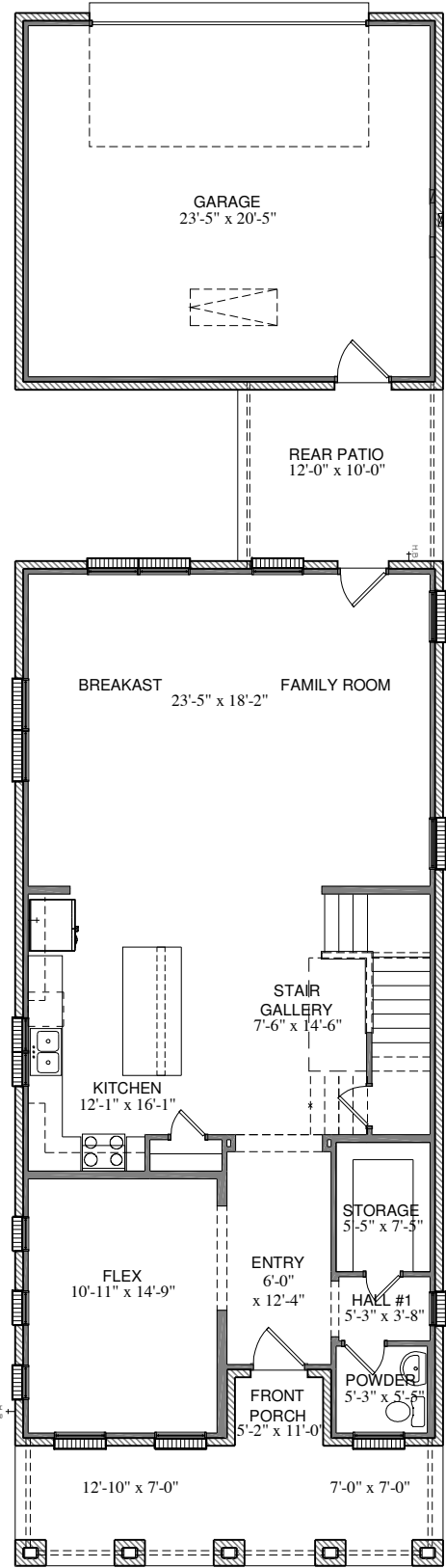

FIRST FLOOR PLAN

**ELEVATION "C"
SQUARE FOOTAGE TOTALS**

1271	1ST FLOOR
1167	2ND FLOOR
316	COVERED PORCHES
550	GARAGE
3304	TOTAL A.U.R.

All plans and elevations are subject to change without prior notice. All Village Homes floor plans & elevations are copyrighted. Village Homes will enforce copyright laws to their fullest extent. All plan numbers are approximations of square footage and may vary with alternate elevations.

Please note: In an effort to continually improve our floor plans and elevations, Village Homes reserves the right to make alterations to the designs without prior notice.

C.25R.2438 CLARE

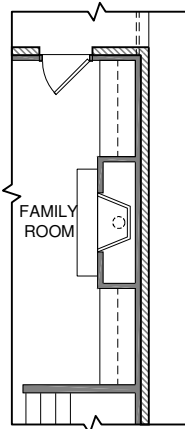

OPT. FIREPLACE
W/ CABINETS

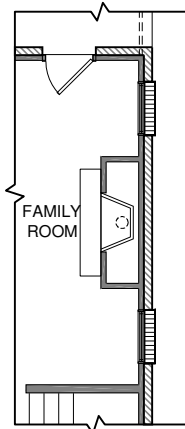

OPT. FIREPLACE

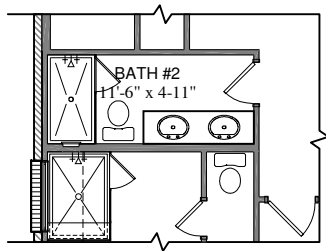

OPT. BATH #2 SHOWER

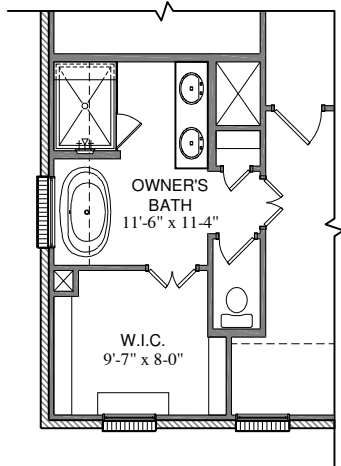

OPT. LUXURY OWNER'S BATH
W/ FREE-STANDING TUB

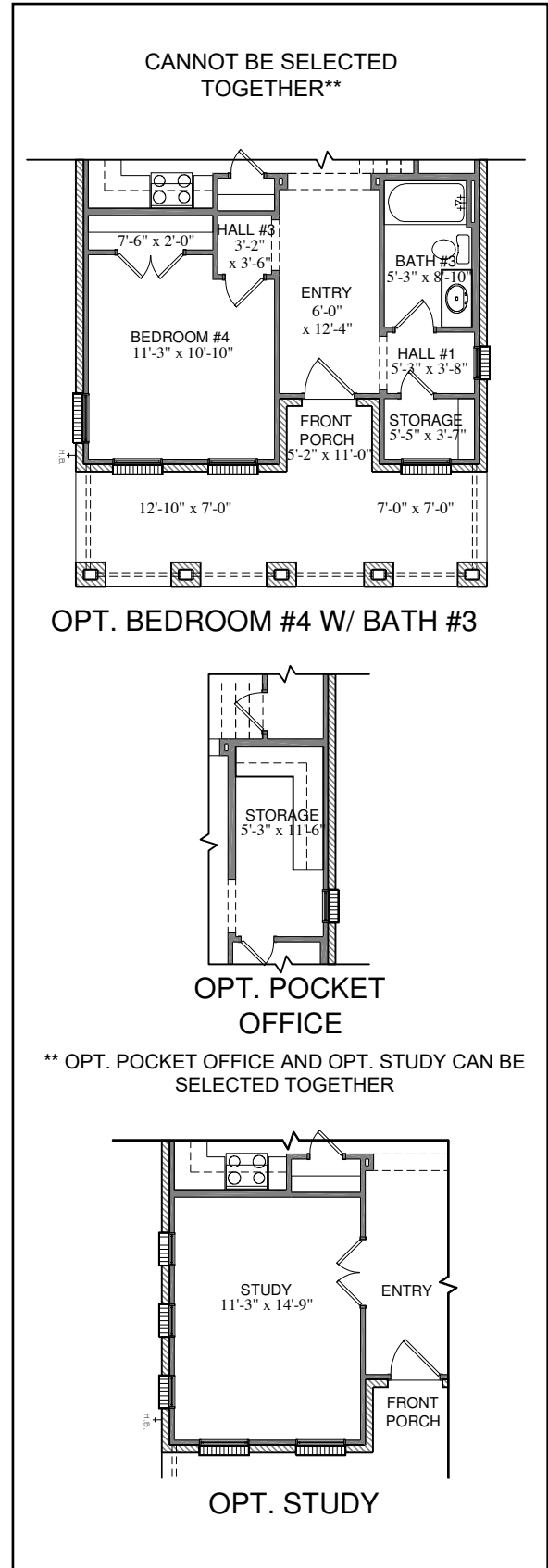

ELEVATION "C"

All plans and elevations are subject to change without prior notice. All Village Homes floor plans & elevations are copyrighted. Village Homes will enforce copyright laws to their fullest extent. All plan numbers are approximations of square footage and may vary with alternate elevations.

Please note: In an effort to continually improve our floor plans and elevations, Village Homes reserves the right to make alterations to the designs without prior notice.